

## Description

A hand crafted Australian made ferrite magnet electric guitar loudspeaker made to replicate typical vintage 60's guitar models. To achieve this materials and processes used in the 60's have been employed to regain the classic vintage sound. This model employs our larger "U" ferrite magnet producing a very efficient loudspeaker and tighter bass. The magnet assembly has been FE optimized and the magnet components CNC machined in house to tight tolerances to achieve high efficiency at minimum weight and finished in e-coat for superior corrosion resistance.

The lighter 30W cone is produced in house from ex Rola tooling under our control from a blend of natural renewable Eucalypt and Hemp fibres; this fibre formulation and processing delivers the classic Australian guitar signature and replicated by many rivals. The paper blend and processing is based upon prior art and research developed and refined over 30 years of in-house paper cone production. The optimum blend optimised from user feedback.

This model employs a copper voice-coil wound onto Kraft paper bobbin to emulate the sixties sound, this prior art produces a nominal 30W power rating. The voice-coil is adhered to the cone body with a selected adhesive to ensure reliable performance but retain the sixties voicing characteristics.

The voice-coil, cone materials, and magnet properties have been selected to emulate the high efficiency, bright top typical of guitar loudspeakers manufactured in the 60's. This model only requires moderate amplifier power for delivery.

This Australian hand crafted model is an excellent choice for serious musicians where high efficiency, classic 60's performance and high reliability are desired.

## Application

Use with amplifiers rated up to 30W per loudspeaker. The "U" model has a tighter bass and more output over the "P" range. Best match with low power vintage style guitar amplification. This model experiences cone breakup at a moderate 15W thereby delivering vintage tone with crunch and overdriven character at rated power typical of guitar speakers made in the 60's.

## Options

Model	Impedance
AC304U30-MI-8	8 ohm
AC304U30-MI-16	16 ohm

*This datasheet applies to our AC304U30-MI-8 model.*



**Technical Data**

*Typical measured Thiele/Small parameters*

Maximum program power	=	30 watt
Thermal power rating	=	30 watt rms
Rated nominal impedance Z	=	8 ohms
Rated frequency range	=	60 - 6000 Hz
Piston sensitivity level	=	98.9 dB SPL
Max SPL @ 1w	=	107 dB SPL
Resonance frequency	=	80 Hz
Mechanical Q Qm	=	18
Electrical Q Qe	=	0.48
Total spk. Q Qts	=	0.47
Diaphragm mass Mmd	=	23.8 gms
Effective diaphragm diameter D	=	25.3 cm
Effective diaphragm area Sd	=	0.050 sq.m.
Vol. equiv to spk compliance Vas	=	48 litres
Mechanical compliance Cms	=	0.131 mm/N
BL product Bl	=	14.1 T.m
Voicecoil diameter d	=	45 mm
Voicecoil material	=	Copper
Bobbin Material	=	Paper
Voicecoil DC resistance Re	=	6.32 ohms
Voicecoil inductance @ 1kHz Lvc	=	0.97 mH
Voicecoil height	=	10.0 mm
Height of air-gap Hg	=	8 mm
Peak linear displacement Xpk	=	1.0 mm
Reference efficiency	=	4.8 %
Speaker total mass	=	3800 gms

*Specifications subject to change without notice.*

**Mounting Details**

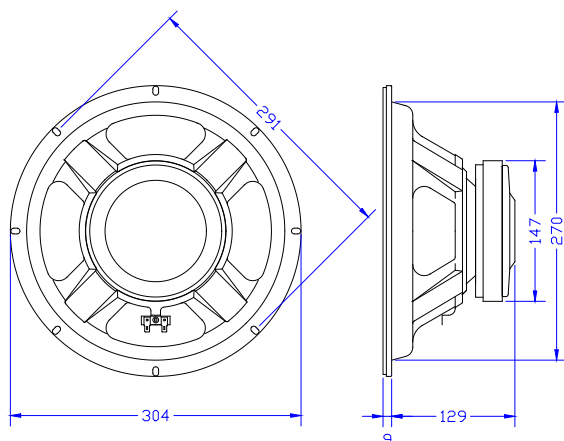

Baffle opening diameter	
front mounting	273 mm
rear mounting	273 mm
Mounting pattern:	
eight 6 x 9 mm slots equi-spaced on	291 mm PCD.
Flange thickness	9 mm

**Frequency Response**



Infinite baffle sound pressure response recorded at 2.83V at one meter.

Blue curve - on axis spl response  
Green curve - 30 degrees off axis response

**Impedance plot**

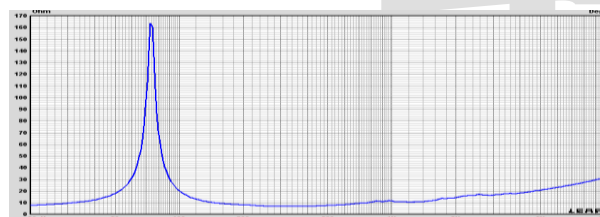

Free-air impedance magnitude plot.